



管 夹 TUBE CLAMPS

(一)概述 INTRODUCTION

1、范围

轻型系列管夹应用于6种尺寸系列的普通机械压力管子，管子外径 $\phi 6-57\text{mm}$ 。

双联系列管夹应用于5种尺寸系列的普通机械压力管子，管子外径 $\phi 6-42\text{mm}$ 。

重型系列管夹应用于10种尺寸系列的高机械压力管子，管子外径 $\phi 8-406\text{mm}$ 。

1、RANGE

Light series clamps can be supplied in 6 series for normal mechanical stress, Tube o.d. 6 to 57mm.

Twin tube clamp series can be supplied in 5 series for normal mechanical stress, Tube o.d. 6 to 42mm.

Heavy series, clamps can be supplied in 10 series for high mechanical stress, Tube o.d. 8 to 406mm.

2、材料特性 MATERIAL PROPERTIES

特性 Properties	聚丙烯 Polypropylene(PP)	尼龙 Polyamide 6 (PA 6)	铝 Aluminum
密度 Density	0.906 g/cm ³	1.12-1.15 g/cm ³	2.65 g/cm ³
弯曲挠度 Flexural Deflection	36N/mm ²	130-200N/mm ²	70N/mm ²
冲击韧性 Impact Resistance	不断 no break	不断 no break	
压缩强度 Compressive Strength	90N/mm ²	120N/mm ²	800-900N/mm ²
弹性模量 Modules of Elasticity	1500N/mm ²	3000N/mm ²	7000N/mm ²
抗拉强度 Tensile Strength	25-35N/mm ²	80-90N/mm ²	180N/mm ²
耐温 Temp Resistance	-30--+90°C	-40--+120°C	300°C
颜色 Colour	绿 green	黑 black	

根据要求可选用其它材料 Other materials on request!

3、订货代号 ORDER CODE

管夹 Tube clamp	1 6 6 8 1-3 20	直径 Diameter
系列 Series		尺寸系列 Clamp Size
L-轻型系列 Light Series		组合 Mounting model
T-双联系列 Twin Tube Clamp series		
H-重型系列 Heavy Series		
材料 Material		
P-聚丙烯 Polypropylene		内表面 Interior Surface
N-尼龙 6 Polyamide 6		G-凹槽型 Grooved
A-铝 Aluminum		S-光滑型 Smooth

对单个零件及附件系列有对应的订货代号，它只根据系列代号变化而变化。
The order codes for single parts and accessories have a unit system for all series, which only varies in the series code.



4、管夹安装的推荐距离

RECOMMENDED DISTANCES FOR INSTALLATION OF CLAMP

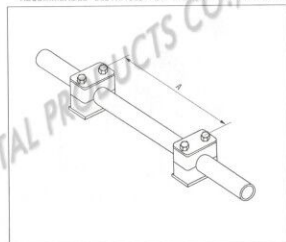

管子外径(mm) Tube o.d.	管子间距(mm) Distances of clamps
6-14	0.9
15-22	1.2
23-28	1.5
30-38	2
40-48.3	2.5
50-57	3
60.3-70	3.4
73-88.9	3.7
90-108	4
114.3-133	4.3
140-161.1	5
168.3-220	5.5
219.1-323.9	6.5
356-406	7.5

当弯头或管端用管夹固定时，应该尽可能近地在弯管的两边。
When an elbow or bend to be supported by the clamps, the clamps should be positioned as close as possible on each side of the bend.



5、装配说明

装配在焊接板上

装配前，为更好地确定管夹的方向，建议先在固定处做好标记，后焊上焊接板，嵌上管夹体的下半部分，放上需固定的管子。再放上另一半管夹体和盖板，用螺钉擦紧。

切忌直接焊接已装好管夹的底板。

装在导轨上

导轨可焊在基础上，或用螺钉固定，随后将导轨螺母推入轨内，并转 90 度，将下半个管夹体嵌入螺母，入上需固定的管子，再放上上半个管夹体和盖板，用螺钉固定。

叠起装配

导轨可焊在基础上，或用螺钉固定，先装上下半个管夹体，放上需固定的管子，再放上上半个管夹体，用螺钉固定，通过防松盖板防止它转动。然后安装第二个管夹，方法同上。

ASSEMBLY INSTRUCTION

Assembly on to metal welding plates

Weld metal welding plates on to a weight adjusted base.

Clip lower half of clamp on to welding plate and insert tube; then add second clamp-half and tighten with screws provided.

DO NOT weld with plastic clamp in position!

Assembly on rail-supports

Rail-supports can

be welded or screwed on with a fastening bracket. Insert rail nuts into rail and turn as far as it will go.(Ensure that spacing is right).

Wedge on lower clamp-half, insert tube, add second clamp-half and tighten with screws provided.

Construction assembly

Weld on welding plate or rail support, or screw on with a fixing bracket. Wedge on lower clamp-half, insert tube, add upper clamp-half and tighten with fixing screws.(Fixing screw to jut out.)

By applying a locking plate to the upper half of the clamp, the fixing screw is prevented from twisting. Then mount the second tube clamp in exactly the same way.

弯管的装配

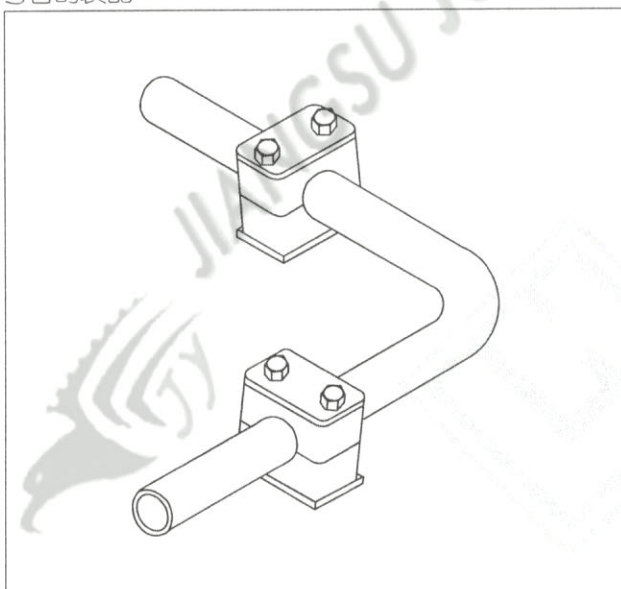

弯配弯管时，应直接在弯管的前部和后部用黎明管夹固定。建议这样的支承点应为固定位置。

螺栓的紧固力矩和管上的轴向夹持力

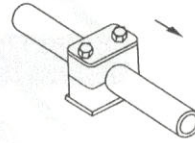

管上的轴的夹持力(根据DIN 3015 第10部分)是一个平均值，它是由3次试验值计算出来的。试验时用一根按照DIN 2448 的 St37 号钢管，温度为 23°C，管上有静摩擦。
管夹在管子的轴向上受到一个列出的测试力(F)时，管夹内的管子不会滑动。

轻型系列(按照DIN 3015 第1部分)

尺寸系列	固定用螺栓 GB5782-86	聚丙烯		尼龙6	
		螺栓紧固力矩(Nm)	管子夹持力F(KN)	螺栓紧固力矩(Nm)	管子夹持力F(KN)
0	M6	8	0.6	10	0.6
1		8	1.1	10	0.7
2		8	1.3	10	0.8
3		8	1.4	10	1.6
4		8	1.5	10	1.7
5		8	1.9	10	2.0
6	8	2.0	10	2.5	

重型系列(按照DIN 3015 第2部分)

尺寸系列	固定用螺栓 GB5782-86	聚丙烯		尼龙6		铝	
		螺栓紧固力矩(Nm)	管子夹持力F(KN)	螺栓紧固力矩(Nm)	管子夹持力F(KN)	螺栓紧固力矩(Nm)	管子夹持力F(KN)
1	M10	12	1.6	20	4.2	30	12.1
2		12	2.9	20	4.5	30	15.1
3		15	3.3	25	5.1	35	15.5
4	M12	30	8.2	40	9.3	55	29.4
5	M16	45	11.0	55	21.0	120	34.9
6	M20	80	14.0	150	25.8	220	50.0
7	M24	110	28.0	200	32.0	250	70.6
8	M30	180	40.0	350	48.0	500	84.5
9						500	181.5
10						600	244.5

双联系列(按照DIN 3015 第3部分)

尺寸系列	固定用螺栓 GB5782-86	聚丙烯		尼龙6	
		螺栓紧固力矩(Nm)	管子夹持力F(KN)	螺栓紧固力矩(Nm)	管子夹持力F(KN)
1	M6	5	0.9	5	0.9
2	M8	12	2.1	12	2.2
3		12	1.9	12	2.0
4		12	2.7	12	2.9
5		8	1.7	8	2.5



(二) 组件与零件 ASSEMBLY AND COMPONENTS





(本产品符合德国标准 DIN3015 Teil1)

订货代号 Order code				管夹底板短, 焊接固定, 用开槽圆柱头螺钉加垫圈压紧管夹。	管夹底板短, 焊接固定, 用内六角螺钉加垫圈压紧管夹。	管夹底板短, 焊接固定, 用外六角螺栓加盖板压紧管夹。	管夹底板用焊接或螺栓固定, 用开槽圆柱头螺钉加垫圈压紧管夹。	管夹底板用焊接或螺栓固定, 用内六角螺钉加垫圈压紧管夹。
TLPG—轻型塑料管夹内孔凹槽型 Light series, polypropylene, inside grooved								
TLPS—轻型塑料管夹内孔光滑 Light series, polypropylene, inside smooth								
TLNG—轻型尼龙管夹内孔凹槽型 Light series, polyamide 6, inside grooved								
TLNS—轻型尼龙管夹内孔光滑 Light series, polyamide 6, inside smooth								
(根据要求, 请调换“订货代号”中的标准缩写“TLPG”部分) (As required, exchange standard abbreviation “TLPG” in column of “order code”)				订货代号 Order code	订货代号 Order code	订货代号 Order code	订货代号 Order code	订货代号 Order code
尺寸系列 Clamp size	外径 mm O.D.	英寸内径 inch I.D.	英寸外径 inch O.D.	订货代号 Order code	订货代号 Order code	订货代号 Order code	订货代号 Order code	订货代号 Order code
0	6	G1/8	3/8	TLPG1-006	TLPG2-006	TLPG3-006	TLPG4-006	TLPG5-006
	6.4			TLPG1-006.4	TLPG2-006.4	TLPG3-006.4	TLPG4-006.4	TLPG5-006.4
	8			TLPG1-008	TLPG2-008	TLPG3-008	TLPG4-008	TLPG5-008
	9.5			TLPG1-009.5	TLPG2-009.5	TLPG3-009.5	TLPG4-009.5	TLPG5-009.5
	10			TLPG1-010	TLPG2-010	TLPG3-010	TLPG4-010	TLPG5-010
	12			TLPG1-012	TLPG2-012	TLPG3-012	TLPG4-012	TLPG5-012
1	6	G1/8	3/8	TLPG1-106	TLPG2-106	TLPG3-106	TLPG4-106	TLPG5-106
	6.4			TLPG1-106.4	TLPG2-106.4	TLPG3-106.4	TLPG4-106.4	TLPG5-106.4
	8			TLPG1-108	TLPG2-108	TLPG3-108	TLPG4-108	TLPG5-108
	9.5			TLPG1-109.5	TLPG2-109.5	TLPG3-109.5	TLPG4-109.5	TLPG5-109.5
	10			TLPG1-110	TLPG2-110	TLPG3-110	TLPG4-110	TLPG5-110
	12			TLPG1-112	TLPG2-112	TLPG3-112	TLPG4-112	TLPG5-112
2	12.7	G1/4	5/8	TLPG1-212.7	TLPG2-212.7	TLPG3-212.7	TLPG4-212.7	TLPG5-212.7
	13.5			TLPG1-213.5	TLPG2-213.5	TLPG3-213.5	TLPG4-213.5	TLPG5-213.5
	14			TLPG1-214	TLPG2-214	TLPG3-214	TLPG4-214	TLPG5-214
	15			TLPG1-215	TLPG2-215	TLPG3-215	TLPG4-215	TLPG5-215
	16	G3/8	5/8	TLPG1-216	TLPG2-216	TLPG3-216	TLPG4-216	TLPG5-216
	17.2			TLPG1-217.2	TLPG2-217.2	TLPG3-217.2	TLPG4-217.2	TLPG5-217.2
	18			TLPG1-218	TLPG2-218	TLPG3-218	TLPG4-218	TLPG5-218
3	19	G1/2	1	TLPG1-319	TLPG2-319	TLPG3-319	TLPG4-319	TLPG5-319
	20			TLPG1-320	TLPG2-320	TLPG3-320	TLPG4-320	TLPG5-320
	21.3			TLPG1-321.3	TLPG2-321.3	TLPG3-321.3	TLPG4-321.3	TLPG5-321.3
	22			TLPG1-322	TLPG2-322	TLPG3-322	TLPG4-322	TLPG5-322
	23			TLPG1-323	TLPG2-323	TLPG3-323	TLPG4-323	TLPG5-323
	25			TLPG1-325	TLPG2-325	TLPG3-325	TLPG4-325	TLPG5-325
4	26.9	G3/4	1	TLPG1-426.9	TLPG2-426.9	TLPG3-426.9	TLPG4-426.9	TLPG5-426.9
	28			TLPG1-428	TLPG2-428	TLPG3-428	TLPG4-428	TLPG5-428
	30			TLPG1-430	TLPG2-430	TLPG3-430	TLPG4-430	TLPG5-430
5	32	G1	1 1/4	TLPG1-532	TLPG2-532	TLPG3-532	TLPG4-532	TLPG5-532
	33.7			TLPG1-533.7	TLPG2-533.7	TLPG3-533.7	TLPG4-533.7	TLPG5-533.7
	35			TLPG1-535	TLPG2-535	TLPG3-535	TLPG4-535	TLPG5-535
	38	G1 1/4	1 1/2	TLPG1-538	TLPG2-538	TLPG3-538	TLPG4-538	TLPG5-538
	40			TLPG1-540	TLPG2-540	TLPG3-540	TLPG4-540	TLPG5-540
	42			TLPG1-542	TLPG2-542	TLPG3-542	TLPG4-542	TLPG5-542
6	44.5	G1 1/2	2	TLPG1-644.5	TLPG2-644.5	TLPG3-644.5	TLPG4-644.5	TLPG5-644.5
	45			TLPG1-645	TLPG2-645	TLPG3-645	TLPG4-645	TLPG5-645
	48			TLPG1-648	TLPG2-648	TLPG3-648	TLPG4-648	TLPG5-648
	50			TLPG1-650	TLPG2-650	TLPG3-650	TLPG4-650	TLPG5-650
	50.8	2 1/4	2	TLPG1-650.8	TLPG2-650.8	TLPG3-650.8	TLPG4-650.8	TLPG5-650.8
	52			TLPG1-652	TLPG2-652	TLPG3-652	TLPG4-652	TLPG5-652
	55			TLPG1-655	TLPG2-655	TLPG3-655	TLPG4-655	TLPG5-655
	57			TLPG1-657	TLPG2-657	TLPG3-657	TLPG4-657	TLPG5-657

如果要求不同的型式, 我们可按分散零件订货 If different combinations are required, they could be ordered as separate components.







(本产品符合德国标准 DIN3015 Teil1)

订货代号 Order code TLPG—轻型塑料管夹内孔凹槽型 Light series, polypropylene inside grooved TLPS—轻型塑料管夹内孔光滑 Light series, polypropylene inside smooth TLNG—轻型尼龙管夹内孔凹槽型 Light series, polyamide 6, inside grooved TLNS—轻型尼龙管夹内孔光滑 Light series, polyamide 6, inside smooth (根据要求, 请调换“订货代号”中的标准缩写 “TLPG”部分) (As required, exchange standard abbreviation “TLPG” in column of “order code”)				管夹底板用焊接或螺栓固定, 用外六角螺栓加盖板压紧管夹 2 clamp halves, weld/ screw plate, cover plate and hex. head bolts	管夹用开槽圆柱头螺钉加垫圈和道轨螺母压紧(在导轨上) 2 clamp halves, rail nuts, slot head screws and washers	管夹用内六角螺钉加垫圈和道轨螺母压紧(在导轨上) 2 clamp halves, rail nuts, socket headscrews and washers	管夹用外六角螺栓加盖板和道轨螺母压紧(在导轨上) 2 clamp halves, rail nuts, cover plate and hex head bolts			
										
尺寸系列 Clamp size	外径 mm O.D.	英寸内径 inch I.D.	英寸外径 Inch O.D.	订货代号 Order code	订货代号 Order code	订货代号 Order code	订货代号 Order code			
0	6	G1/8	1/4	TLPG6-006	TLPG9-006	TLPG10-006	TLPG12-006			
	6.4			TLPG6-006.4	TLPG9-006.4	TLPG10-006.4	TLPG12-006.4			
	8			TLPG6-008	TLPG9-008	TLPG10-008	TLPG12-008			
	8.5			TLPG6-009.5	TLPG9-009.5	TLPG10-009.5	TLPG12-009.5			
	10			TLPG6-010	TLPG9-010	TLPG10-010	TLPG12-010			
	12			TLPG6-012	TLPG9-012	TLPG10-012	TLPG12-012			
1	6	G1/8	1/4	TLPG6-106	TLPG9-106	TLPG10-106	TLPG12-106			
	6.4			TLPG6-106.4	TLPG9-106.4	TLPG10-106.4	TLPG12-106.4			
	8			TLPG6-108	TLPG9-108	TLPG10-108	TLPG12-108			
	8.5			TLPG6-109.5	TLPG9-109.5	TLPG10-109.5	TLPG12-109.5			
	10			TLPG6-110	TLPG9-110	TLPG10-110	TLPG12-110			
	12			TLPG6-112	TLPG9-112	TLPG10-112	TLPG12-112			
2	12.7	G1/4	1/2	TLPG6-212.7	TLPG9-212.7	TLPG10-212.7	TLPG12-212.7			
	13.5			TLPG6-213.5	TLPG9-213.5	TLPG10-213.5	TLPG12-213.5			
	14			TLPG6-214	TLPG9-214	TLPG10-214	TLPG12-214			
	15			TLPG6-215	TLPG9-215	TLPG10-215	TLPG12-215			
	16	G3/8	5/8	TLPG6-216	TLPG9-216	TLPG10-216	TLPG12-216			
	17.2			TLPG6-217.2	TLPG9-217.2	TLPG10-217.2	TLPG12-217.2			
	18			TLPG6-218	TLPG9-218	TLPG10-218	TLPG12-218			
	19			TLPG6-319	TLPG9-319	TLPG10-319	TLPG12-319			
3	20	G1/2	3/4	TLPG6-320	TLPG9-320	TLPG10-320	TLPG12-320			
	21.3			TLPG6-321.3	TLPG9-321.3	TLPG10-321.3	TLPG12-321.3			
	22			TLPG6-322	TLPG9-322	TLPG10-322	TLPG12-322			
	23			TLPG6-323	TLPG9-323	TLPG10-323	TLPG12-323			
	25			TLPG6-325	TLPG9-325	TLPG10-325	TLPG12-325			
	26.9			TLPG6-426.9	TLPG9-426.9	TLPG10-426.9	TLPG12-426.9			
4	28	G3/4	1	TLPG6-428	TLPG9-428	TLPG10-428	TLPG12-428			
	30			TLPG6-430	TLPG9-430	TLPG10-430	TLPG12-430			
	32			G1	1 1/4	TLPG6-532	TLPG9-532	TLPG10-532	TLPG12-532	
	33.7					TLPG6-533.7	TLPG9-533.7	TLPG10-533.7	TLPG12-533.7	
	35					1 1/2	TLPG6-535	TLPG9-535	TLPG10-535	TLPG12-535
	38						TLPG6-538	TLPG9-538	TLPG10-538	TLPG12-538
40	TLPG6-540	TLPG9-540	TLPG10-540				TLPG12-540			
42	TLPG6-542	TLPG9-542	TLPG10-542				TLPG12-542			
6	44.5	G1 1/2	1 3/4	TLPG6-644.5	TLPG9-644.5	TLPG10-644.5	TLPG12-644.5			
	45			TLPG6-645	TLPG9-645	TLPG10-645	TLPG12-645			
	48			TLPG6-648	TLPG9-648	TLPG10-648	TLPG12-648			
	50		2	TLPG6-650	TLPG9-650	TLPG10-650	TLPG12-650			
	50.8			TLPG6-650.8	TLPG9-650.8	TLPG10-650.8	TLPG12-650.8			
	52			TLPG6-652	TLPG9-652	TLPG10-652	TLPG12-652			
	55			TLPG6-655	TLPG9-655	TLPG10-655	TLPG12-655			
	57			2 1/4	TLPG6-657	TLPG9-657	TLPG10-657	TLPG12-657		

如果要求不同的型式, 我们可按分散零件订货 If different combinations are required, they could be ordered as components.

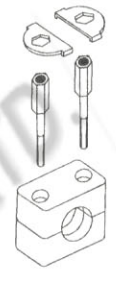
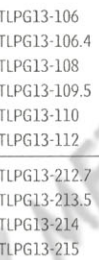
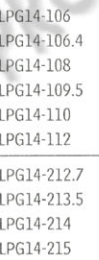
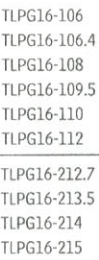
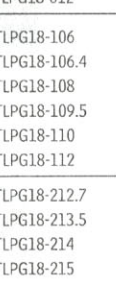
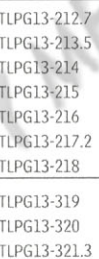
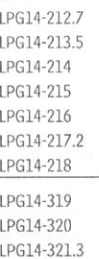
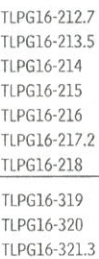
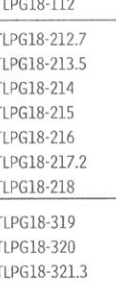
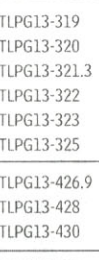
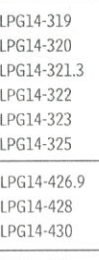
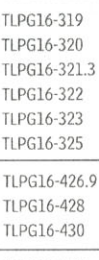

(本产品符合德国标准 DIN3015 Teil1)

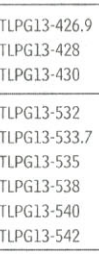
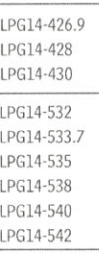
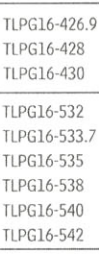
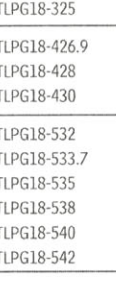
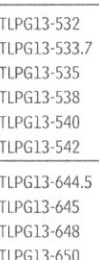
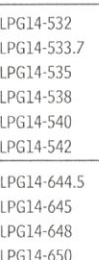
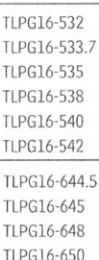
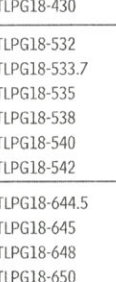
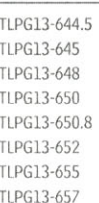
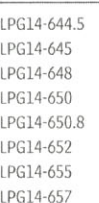
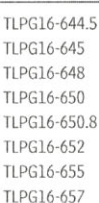
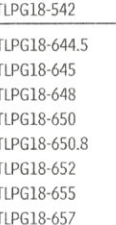
订货代号 Order code TLPG—轻型塑料管夹内孔凹槽型 Light series, polypropylene, inside grooved TLPS— 轻型塑料管夹内孔光滑 Light series, polypropylene, inside smooth TLNG— 轻型尼龙管夹内孔凹槽型 Light series, polyamide 6, inside grooved TLNS— 轻型尼龙管夹内孔光滑 Light series, polyamide 6, inside smooth (根据要求, 请调换“订货代号”中的标准 缩写为“TLPG”部分) (As required, exchange standard abbreviation “TLPG” in column of “order code”)				管夹用开槽圆柱头螺钉 加垫圈和其它底板或叠 加另一管夹压紧 2 clamp halves, slot head screws and washers		管夹用内六角螺钉加垫 圈和其它底板或叠加另 一管夹压紧 2 clamp halves, socket head screws and washers		管夹用外六角螺栓加盖 板和其它底板或叠加另 一管夹压紧 2 clamp halves, cover plate and hex head bolts		管夹用叠加螺栓加防 松盖板和其它底板或 叠加另一管夹压紧 2 clamp halves, stacking bolts and locking plate	
				尺寸系列 Clamp size	外径 mm O.D.	英寸内径 Inch I.D.	英寸外径 Inch O.D.	订货代号 Order code	订货代号 Order code	订货代号 Order code	订货代号 Order code
0	6	G1/8	1/4	TLPG13-006	TLPG14-006	TLPG16-006	TLPG18-006				
	6.4			TLPG13-006.4	TLPG14-006.4	TLPG16-006.4	TLPG18-006.4				
	8			TLPG13-008	TLPG14-008	TLPG16-008	TLPG18-008				
	9.5			TLPG13-009.5	TLPG14-009.5	TLPG16-009.5	TLPG18-009.5				
	10			TLPG13-010	TLPG14-010	TLPG16-010	TLPG18-010				
	12			TLPG13-012	TLPG14-012	TLPG16-012	TLPG18-012				
1	6	G1/8	1/4	TLPG13-106	TLPG14-106	TLPG16-106	TLPG18-106				
	6.4			TLPG13-106.4	TLPG14-106.4	TLPG16-106.4	TLPG18-106.4				
	8			TLPG13-108	TLPG14-108	TLPG16-108	TLPG18-108				
	9.5			TLPG13-109.5	TLPG14-109.5	TLPG16-109.5	TLPG18-109.5				
	10			TLPG13-110	TLPG14-110	TLPG16-110	TLPG18-110				
	12			TLPG13-112	TLPG14-112	TLPG16-112	TLPG18-112				
2	12.7	G1/4	1/2	TLPG13-212.7	TLPG14-212.7	TLPG16-212.7	TLPG18-212.7				
	13.5			TLPG13-213.5	TLPG14-213.5	TLPG16-213.5	TLPG18-213.5				
	14			TLPG13-214	TLPG14-214	TLPG16-214	TLPG18-214				
	15			TLPG13-215	TLPG14-215	TLPG16-215	TLPG18-215				
	16	G3/8	5/8	TLPG13-216	TLPG14-216	TLPG16-216	TLPG18-216				
	17.2			TLPG13-217.2	TLPG14-217.2	TLPG16-217.2	TLPG18-217.2				
	18			TLPG13-218	TLPG14-218	TLPG16-218	TLPG18-218				
	19			TLPG13-319	TLPG14-319	TLPG16-319	TLPG18-319				
3	20	G1/2	3/4	TLPG13-320	TLPG14-320	TLPG16-320	TLPG18-320				
	21.3			TLPG13-321.3	TLPG14-321.3	TLPG16-321.3	TLPG18-321.3				
	22			TLPG13-322	TLPG14-322	TLPG16-322	TLPG18-322				
	23			TLPG13-323	TLPG14-323	TLPG16-323	TLPG18-323				
	25			TLPG13-325	TLPG14-325	TLPG16-325	TLPG18-325				
	25			1	TLPG13-325	TLPG14-325	TLPG16-325				
4	26.9	G3/4		TLPG13-426.9	TLPG14-426.9	TLPG16-426.9	TLPG18-426.9				
	28			TLPG13-428	TLPG14-428	TLPG16-428	TLPG18-428				
	30			TLPG13-430	TLPG14-430	TLPG16-430	TLPG18-430				
5	32	G1	1 1/4	TLPG13-532	TLPG14-532	TLPG16-532	TLPG18-532				
	33.7			TLPG13-533.7	TLPG14-533.7	TLPG16-533.7	TLPG18-533.7				
	35			TLPG13-535	TLPG14-535	TLPG16-535	TLPG18-535				
	38	G1 1/4	1 1/2	TLPG13-538	TLPG14-538	TLPG16-538	TLPG18-538				
	40			TLPG13-540	TLPG14-540	TLPG16-540	TLPG18-540				
	42			TLPG13-542	TLPG14-542	TLPG16-542	TLPG18-542				
6	44.5	G1 1/2	1 3/4	TLPG13-644.5	TLPG14-644.5	TLPG16-644.5	TLPG18-644.5				
	45			TLPG13-645	TLPG14-645	TLPG16-645	TLPG18-645				
	48			TLPG13-648	TLPG14-648	TLPG16-648	TLPG18-648				
	50			TLPG13-650	TLPG14-650	TLPG16-650	TLPG18-650				
	50.8	2		TLPG13-650.8	TLPG14-650.8	TLPG16-650.8	TLPG18-650.8				
	52			TLPG13-652	TLPG14-652	TLPG16-652	TLPG18-652				
	55			TLPG13-655	TLPG14-655	TLPG16-655	TLPG18-655				
	57			TLPG13-657	TLPG14-657	TLPG16-657	TLPG18-657				

如果要求不同的型式, 我们可按分散零件订货 If different combinations are required, they would be ordered as components.



(本产品符合德国标准 DIN3015 Teil1)

尺寸系列 Clamp size				TLPG 型管夹 2 clamp halves TLPG				焊接短底板 Welding plate short			焊接或螺栓装底板 Weld / screw plate						
				订货代号 Order code	尺寸 Size				订货代号 Order code	尺寸 Size		订货代号 Order code	尺寸 Size				
外径 mm O.D. a	英寸内径 Inch I.D.	英寸外径 Inch O.D.					d	e	δ	Order code	d	e	f	n	δ		
0	6	G1/8	1/4	TLPG-006 TLPG-006.4 TLPG-008 TLPG-009.5 TLPG-010 TLPG-012	28	27	-	13.5	TL - A0	-	30	3	TL - B0	-	58 44 6.5 3		
	6.4															5/16	3/8
	8																
	9.5																
	10																
	12																
1	6	G1/8	1/4	TLPG-106 TLPG-106.4 TLPG-108 TLPG-109.5 TLPG-110 TLPG-112	34	27	20	13.5	TL - A1	20	36	3	TL - B1	20	64 50 6.5 3		
	6.4															5/16	3/8
	8																
	9.5																
	10																
	12																
2	12.7	G1/4	1/2	TLPG-212.7 TLPG-213.5 TLPG-214 TLPG-215 TLPG-216 TLPG-217.2 TLPG-218	40	33	26	16.5	TL - A2	26	42	3	TL - B2	26	70 56 6.5 3		
	13.5															5/8	
	14																
	15																
	16																
	17.2															G3/8	
18																	
3	19	G1/2	3/4	TLPG-319 TLPG-320 TLPG-321.3 TLPG-322 TLPG-323 TLPG-325	48	35	33	17.5	TL - A3	33	50	3	TL - B3	33	78 64 6.5 3		
	20															1	
	21.3																
	22																
	23																
	25																
4	26.9	G3/4	1	TLPG-426.9 TLPG-428 TLPG-430	57	42	40	21	TL - A4	40	59	3	TL - B4	40	87 73 6.5 3		
	28																
	30																
5	32	G1	1 1/4	TLPG-532 TLPG-533.7 TLPG-535 TLPG-538 TLPG-540 TLPG-542	70	58	52	29	TL - A5	52	72	3	TL - B5	52	100 86 6.5 3		
	33.7															1 1/2	
	35																
	38																
	40																
	42															G1/4	
6	44.5	G1 1/2	1 3/4	TLPG-644.5 TLPG-645 TLPG-648 TLPG-650 TLPG-650.8 TLPG-652 TLPG-655 TLPG-657	86	66	66	33	TL - A6	66	88	3	TL - B6	66	116 100 6.5 3		
	45															2	
	48																
	50																
	50.8																
	52																
	55															2 1/4	
	57																



(本产品符合德国标准 DIN3015 Teil1)

尺寸系列 Clamp size	双联焊接底板 Twin welding plate				多联焊接底板 Multiple weld plate				安装导轨 Mounting rail		导轨螺母 Rail nut					
	订货代号 Order code	尺寸 Size				订货代号 Order code	尺寸 Size				订货代号 Order code	尺寸 Size				
		d	a	e	δ		d	a	e	δ		h	a	b	c	
0	TL-C0	-	30	61	3	TL-D0 (10联)	-	30	298	3	TL-E1	11 (1米)	TL-F	25.4 10.4 12		
1	TL-C1	20	35	69	3	TL-D1 (10联)	20	35	349	3						
2	TL-C2	26	43	86	3	TL-D2 (10联)	26	43	427	3						
3	TL-C3	33	52	104	3	TL-D3 (10联)	33	52	516	3					TL-E2	14 (1米)
4	TL-C4	40	60	117	3	TL-D4 (5联)	40	60	297	3					TL-E3	30 (1米)
5	TL-C5	52	75	145	3	TL-D5 (5联)	52	75	370	3						
6	TL-C6	66	90	176	3	TL-D6 (5联)	66	90	446	3						



(本产品符合德国标准 DIN3015 Teil1)

尺寸系列 Clamp size	盖板 Cover plate			开槽圆柱头螺钉 Slot head screw (GB65-85) d × I	内六角螺钉 Socket head screw (GB70-85) d × I	六角头螺栓 Hexagon head bolt (GB5782-86) d × I	叠加螺栓 Stacking bolt		防松盖板 Locking plate		
	订货代号 Order code	尺寸 Size					订货代号 Order code	尺寸 Size		订货代号 Order code	
		b	d					δ	a		b
0	TL-G0	-	-	3	M6 × 20	M6 × 20	M6 × 30	TL-H0	20	34	
1	TL-G1	34	20	3	M6 × 20	M6 × 20	M6 × 30	TL-H1	20	34	
2	TL-G2	40	26	3	M6 × 25	M6 × 25	M6 × 35	TL-H2	25	39	
3	TL-G3	48	33	3	M6 × 30	M6 × 30	M6 × 40	TL-H3	30	44	TL-L
4	TL-G4	57	40	3	M6 × 35	M6 × 35	M6 × 45	TL-H4	35	49	
5	TL-G5	70	52	3	M6 × 50	M6 × 50	M6 × 60	TL-H5	50	64	
6	TL-G6	86	66	3	M6 × 60	M6 × 60	M6 × 70	TL-H6	60	74	